

CQ2 Series Compact Cylinder



CDQ2B 20 x 25D



CDQ2B 40 x 25

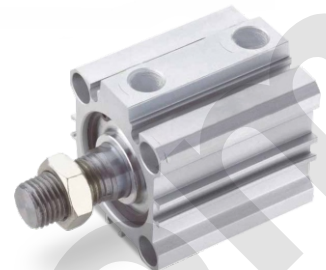

CQ2B 32 x 30-M

Ordering Code

CQ2



12

×

10

D



Series Code

CQ2:Normal Type
CDQ2:Attach magnet Type

Mounting Style

B:With through bore
A:With female thread on both ends

Cylinder Bore

Single action:12mm-50mm
Double action:12mm-100mm

Stroke

0~100mm

Action

D:Double action
S:Single action(with spring return)
T:Single action(with spring extent)

Cylinder body (optional)

Blank:Inner Thread
M:Outer Thread
C:With Cushion

Specification

Bore(mm)	12	16	20	25	32	40	50	63	80	100
Working Medium	Air									
Motion Pattern	Double action/Single Action Extrusion type/Single Action Drawing-in Type									
Ensured Pressure Resistance	15.3kgf/cm ² (1.5Mpa)									
Max.pressure	10.2kgf/cm ² (1.0Mpa)									
Environment And Fluid Temp	5~+60 C									
Thread Type	Inner Thread(Standard)/Outer Thread(Optional)									
Buffering	NO									
Margin of Stroke Error(mm)	±0.0									
Installation	Through Hole (Standard), Inner size on the two sides(Optional)									
Port size	M5×0.8				G1/8"			G1/4"		G3/8"

Note:Pls Confirm Single Type Can't With Cushion.

Overall Dimensions

Through Hole Type/CQ2B Series

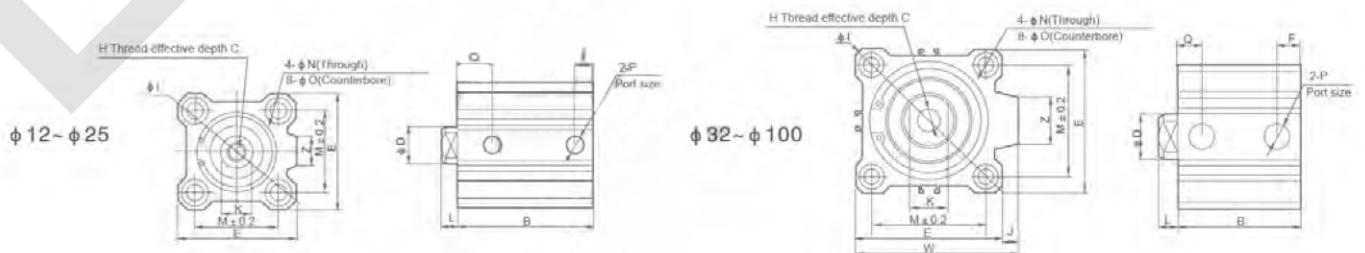

CQ2 Series Compact Cylinder

Dimension Sheet(Double Action)

Model	Stroke range (mm)	B	ΦD	E	F	H	C	ΦI	J	K	L	M	ΦN	ΦO	P	Q	W	Z
CQ2B12-□D	5-30	17+st	6	25	5	M3×0.5	6	32	-	5	3.5	15.5	3.5	6.5 depth 3.5	M5×0.8	7.5	-	-
CQ2B16-□D	5-30	18.5+st	8	29	5.5	M4×0.7	8	38	-	6	3.5	20	3.5	6.5 depth 3.5	M5×0.8	8	-	10
CQ2B20-□D	5-50	19.5+st	10	36	5.5	M6×0.8	7	47	-	8	4.5	25.5	5.5	9 depth 7	M5×0.8	9	-	10
CQ2B25-□D	5-50	22.5+st	12	40	5.5	M8×1.0	12	52	-	10	5	28	5.5	9 depth 7	M5×0.8	11	-	10
CQ2B32-□D	5 10-50	23+st	16	45	5.5 7.5	M8×1.25	13	60	4.5	14	7	34	5.5	9 depth 7	M5×0.8 1/8	11.5 10.5	49.5	18
CQ2B40-□D	5-50	28.5+st	16	52	8	M8×1.25	13	69	5	14	7	40	5.5	9 depth 7	1/8	11	57	18
CQ2B50-□D	10-50	30.5+st	20	64	10.5	M10×1.5	15	86	7	17	8	50	6.6	11 depth 8	1/4	10.5	71	22
CQ2B63-□D	10-50	36+st	20	77	10.5	M10×1.5	15	103	7	17	8	60	9	14 depth 10.5	1/4	15	84	22
CQ2B80-□D	10-50	43.5+st	25	98	12.5	M16×2.0	21	132	6	22	10	77	11	17.5 depth 13.5	3/8	16	104	26
CQ2B100-□D	10-50	53+st	30	117	13	M20×2.5	27	156	6.5	27	12	94	11	17.5 depth 13.5	3/8	23	123.5	26

Note 2) Long Stroke

Model	Stroke (mm)	B	F	P	Q
32	75,100	33	7.5	1/8	10.5
40	75,100	39.5	8	1/8	11
50	75,100	40.5	10.5	1/4	10.5
63	75,100	46	10.5	1/4	15
80	75,100	53.5	12.5	3/8	16
100	75,100	63	13	3/8	23

St=Stroke

Note 1)The standard stroke is at a distance of each 5 mm.

Note 2)The stroke between 55mm-100mm(55,60,65,70,80,85,90,95,)need to be added thickness of 5,10,15 or 20mm pad.

Note 3)External dimensions with bumper are same as standard type as shown above.

Dimension Sheet(Single Action)

Model	B			ΦD	E	F		H	C	ΦI	J	K	L	M	ΦN	ΦO	P			Q		W	Z	
	5st	10st	20st			5st	10st										5st	10st	20st	5st	10st			
CQ2B12-□S	22	27	-	6	25	5	5	M3×0.5	6	32	-	5	3.5	15.5	3.5	6.5 depth 3.5	M5×0.8	-	7.5	7.5	-	-	-	-
CQ2B16-□S	23.5	28.5	-	8	29	5.5	5.5	M4×0.7	8	38	-	6	3.5	20	3.5	6.5 depth 3.5	M5×0.8	-	8	8	-	10	-	-
CQ2B20-□S	24.5	29.5	-	10	36	5.5	5.5	M5×0.8	7	47	-	8	4.5	25.5	5.5	9 depth 7	M5×0.8	-	9	9	-	10	-	-
CQ2B25-□S	27.5	32.5	-	12	40	5.5	5.5	M6×1.0	12	52	-	10	5	28	5.5	9 depth 7	M5×0.8	-	11	11	-	10	-	-
CQ2B32-□S	28	33	-	16	45	5.5	7.5	M8×1.25	13	60	4.5	14	7	34	5.5	9 depth 7	M5×0.8	1/8	-	11.5	11.5	49.5	18	
CQ2B40-□S	34.5	39.5	-	16	52	8	8	M8×1.25	13	69	5	14	7	40	5.5	9 depth 7	1/8	-	11	11	57	18		
CQ2B50-□S	-	40.5	50.5	20	64	10.5	10.5	M10×1.5	15	86	7	17	8	50	6.6	11 depth 8	-	1/4	10.5	10.5	71	22		

St=Stroke

Outer Thread Type

(Inner Thread Type)/CQ2A

Single Action (with Spring extent) φ 12~ φ 50

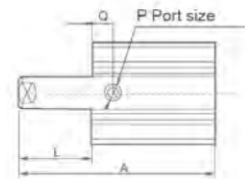

Outer Thread Type

Note3)Inner Thread Type

Single Action (with Spring extent)

Bore(mm)	C	X	ΦD	H	L	K
12	9	10.5	6	M5×0.8	14	5
16	10	12	8	M6×1.0	15.5	6
20	12	14	10	M8×1.25	18.5	8
25	15	17.5	12	M10×1.25	22.5	10
32	10.5	13.5	16	M14×1.5	28.5	14
40	20.5	23.5	16	M14×1.5	28.5	14
50	26	28.5	20	M18×1.5	33.5	17
63	26	28.5	20	M18×1.5	33.5	17
80	32.5	35.5	25	M22×1.5	43.5	22
100	32.5	35.5	30	M26×1.5	43.5	27

Bore(mm)	O	R
12	M4×0.7	7
16	M4×0.7	7
20	M6×1.0	10
25	M6×1.0	10
32	M6×1.0	10
40	M6×1.0	10
50	M8×1.25	14
63	M10×1.5	18
80	M12×1.75	22
100	M12×1.75	22

Bore (mm)	A			L		
	5st	10st	20st	5st	10st	20st
12	30.5	40.5	-	8.5	13.5	-
16	32	42	-	8.5	13.5	-
20	34	44	-	9.5	14.5	-
25	37.5	47.5	-	10	15	-
32	40	50	-	12	17	-
40	46.5	56.5	-	12	17	-
50	-	58.5	78.5	-	18	28

External dimensions with bumper are same as standard type as shown above.

CDQ2 Series Compact Cylinder

Overall Dimensions

CDQ2B Series

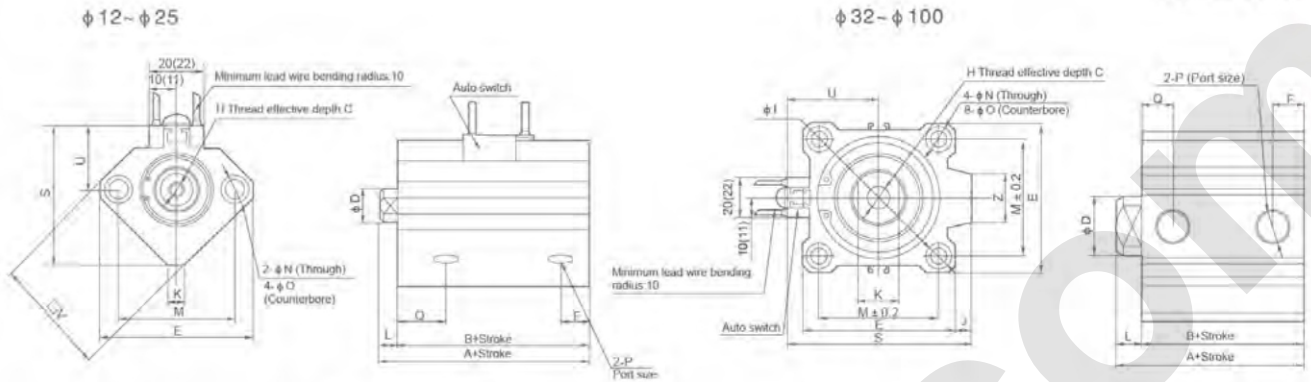

Dimension Sheet(Double Action)

Model	Stroke range (mm)	A	B	ΦD	E	F	H	C	ΦI	J	K	L	M	ΦN	ΦO	P	Q	S	U	V	Z
CDQ2B12	5~30	31.5	28	6	32	6.5	M3×0.5	6	-	-	5	3.5	22	3.5	6.5 depth 3.5	M5×0.8	11	35.5	19.5	25	-
CDQ2B16	5~30	34	30.5	8	38	5.5	M4×0.7	8	-	-	6	3.5	28	3.5	6.5 depth 3.5	M5×0.8	10	41.5	22.5	29	-
CDQ2B20	5~50	36	31.5	10	46.8	5.5	M5×0.8	7	-	-	8	4.5	36	5.5	9 depth 7	M5×0.8	10.5	48	24.5	36	-
CDQ2B25	5~50	37.5	32.5	12	52	5.5	M6×1.0	12	-	-	10	5	40	5.5	9 depth 7	M5×0.8	11	53.5	27.5	40	-
CDQ2B32	5~50	40	33	16	45	7.5	M8×1.25	13	60	4.5	14	7	34	5.5	9 depth 7	1/8	10.5	58.5	31.5	-	18
CDQ2B40	5~50	46.5	39.5	16	52	8	M8×1.25	13	69	5	14	7	40	5.5	9 depth 7	1/8	11	66	35	-	18
CDQ2B50	10~50	48.5	40.5	20	64	10.5	M10×1.5	15	86	7	17	8	50	6.6	11 depth 8	1/4	10.5	80	41	-	22
CDQ2B63	10~50	54	46	20	77	10.5	M10×1.5	15	103	7	17	8	60	9	14 depth 10.5	1/4	15	93	47.5	-	22
CDQ2B80	10~50	63.5	53.5	25	98	12.5	M16×2.0	21	132	6	22	10	77	11	17.5 depth 13.5	3/8	16	112.5	57.5	-	26
CDQ2B100	10~50	75	63	30	117	13	M20×2.5	27	156	6.5	27	12	94	11	17.5 depth 13.5	3/8	23	132.5	67.5	-	26

Note2) (Long Stroke)

Model	Stroke (mm)	A	B	F	P	Q
32	75,100	40	33	7.5	1/8	10.5
40	75,100	46.5	39.5	8	1/8	11
50	75,100	48.5	40.5	10.5	1/4	10.5
63	75,100	54	46	10.5	1/4	15
80	75,100	63.5	53.5	12.5	3/8	16
100	75,100	75	63	13	3/8	23

Note 1)The standard stroke is at a distance of each 5 mm.

Note 2)The stroke between 55mm-100mm(55,60,65,70,80,85,90,95,)need to be added thickness of 5,10,15 or 20mm pad.

Note 3)External dimensions with rumper are same as standard type as shown above.

Note 4)The stroke of cylinder in 5 mm can be fixed only one magnetism switch

Note3)Inner Thread Type

Bore (mm)	O	R
12	M4×0.7	7
16	M4×0.7	7
20	M6×1.0	10
25	M6×1.0	10
32	M6×1.0	10
40	M6×1.0	10
50	M8×1.25	14
63	M10×1.5	18
80	M12×1.75	22
100	M12×1.75	22

Outer Thread type

Bore (mm)	C	X	ΦD	H	L	K
12	9	10.5	6	M5×0.8	14	5
16	10	12	8	M6×1.0	15.5	6
20	12	14	10	M8×1.25	18.5	8
25	15	17.5	12	M10×1.25	22.5	10
32	20.5	23.5	16	M14×1.5	28.5	14
40	20.5	23.5	16	M14×1.5	28.5	14
50	26	28.5	20	M18×1.5	33.5	17
63	26	28.5	20	M18×1.5	33.5	17
80	32.5	35.5	25	M22×1.5	43.5	22
100	32.5	35.5	30	M26×1.5	43.5	27

Inner Thread Type CDQ2A

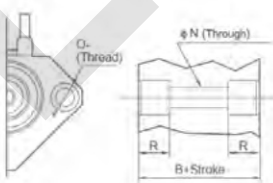

Outer Thread type

